

Mirror | Ice | Glass

Description and Use

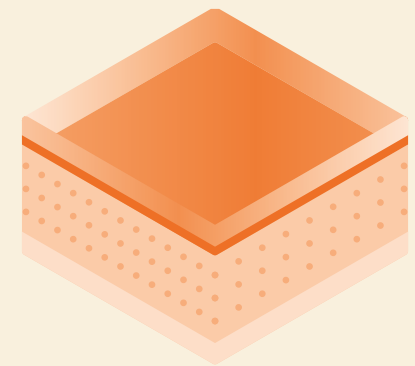
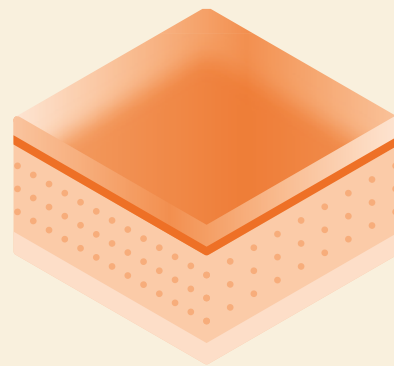
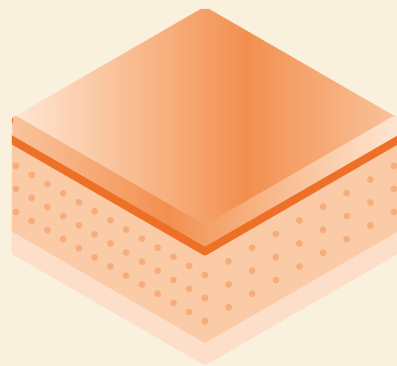

SM 'art[®]
Surface Materials

Designed and made in Italy

Company

We are a dynamic and constantly evolving company that has made innovation its mission, adopting a new creative and productive approach.

We design and produce decorative panels and laminates.

We aim to create astounding design materials with a strong **Made in Italy** connotation, not only as a concept, but indeed as the majority of the raw materials we use come from Italy.

By investing in **equipment and valuable raw materials**, we are able to conceive and craft unique decors and finishes in order to create products that convey emotions, materials with a soul.

Through collaboration with **architects and designers**, the artists of today, we want to create a hotbed of ideas that allows us to pursue the dream of a high-end bottega.



Mirror, Ice and Glass

MIRROR, ICE and GLASS are all made from the same types of raw materials.

The decorative side is always made of **transparent PMMA** (polymethyl methacrylate), which has different effects and a protective film. It is glued onto an MDF core of various thicknesses with polyurethane glue, and balanced with compact PS (polystyrene). The PS is always the same thickness as the PMMA.

MIRROR is available in five colours of glossy PMMA.

AM01 Argento is 2 mm thick and is available in an **HC version** with excellent micro-scratch resistance or an **ST version** with 'standard' resistance.

The other four colours are 3 mm thick and are available in the **ST version**.

Ice, a frosted glass effect, is composed of 2 mm thick, transparent, matt and textured PMMA, coated on the back.

Glass is produced using 2 mm thick glossy PMMA with a back coating and is available in the **HC version**.

HC (hard coated) PMMA receives a surface treatment that greatly increases its resistance to abrasion and chemicals compared to **ST (standard) PMMA**.

The results of the **Martindale test** shown here compare the two qualities.

There is a substantial difference. The test involves rubbing the surface with an abrasive cloth using a laboratory machine that performs 150 oscillations.



PMMA HC **GRADE 5**



PMMA ST **GRADE 2**

Mirror, Ice and Glass

Mirror

AM01 ARGENTO

TRANSPARENT PMMA
GLOSSY HC
UV PROTECTED
MIRROR COATED
ON THE BACK

CORE

PS

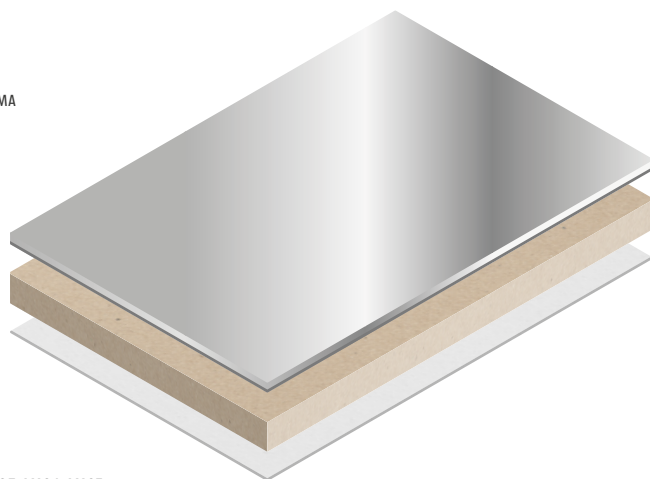

*cod. AM04-AM05-AM06-AM07
PMMA GLOSSY UV PROTECTED

Ice

TRANSPARENT PMMA
FROSTED ST
UV PROTECTED
COATED ON THE BACK

CORE

PS

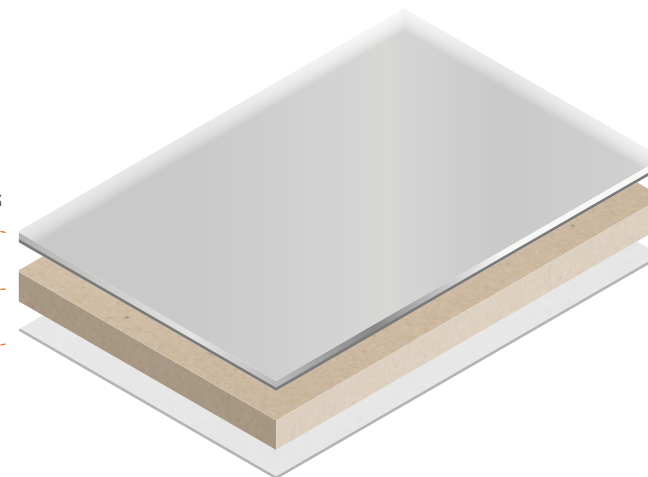

Glass

TRANSPARENT PMMA
GLOSSY HC
UV PROTECTED
COATED ON THE BACK

CORE

PS

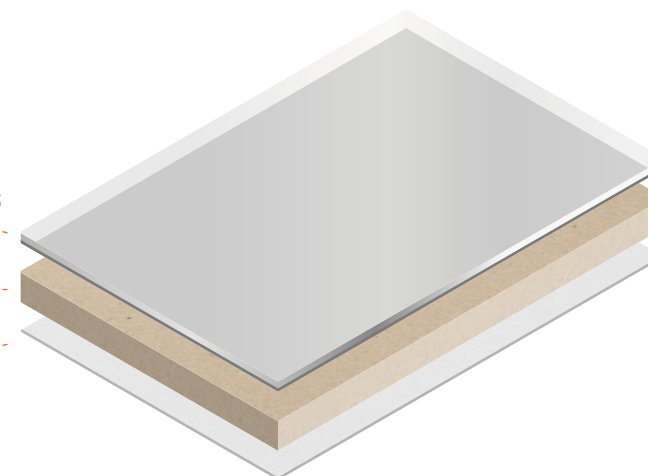

Why is it better than glass?

Mirror, Ice and Glass are **PMMA extruded sheets** and they show various advantages compared to glass.

- Higher transparency: unique brilliance and depth
- Higher impact and crack resistance (11 times stronger than glass)
- Higher safety: PMMA does not shatter
- Lower weight (approximately 50 % that of glass)
- Easy to process with ordinary wood working tools, i.e. on the installation site

Sizes and substrates

Mirror, Ice and Glass products are available in **3050x2050 mm** format. Furthermore, the panels have the same format as TFT panels, which simplifies logistics management.

This product uses **14 mm MDF** as the standard core. Currently, finished panels with a thickness of 18 mm are available for Mirror AM01, Ice and Glass products, while Mirror products in colour variants are available in thickness of 20 mm. **Other substrates** intended for the TFT range and special panels are also available.

UV Resistance

All the PMMA used in our products is **treated to protect it against UV rays**, preventing yellowing and guaranteeing a 10-year lifespan for indoor use.

Expansion

The panels are manufactured in a symmetric composition and at a **controlled room temperature**. The two plastic coatings have higher thermal expansion than the wood panel but, as they are balanced, the expansion is equalised.

Any eventual tension caused by transporting the panels in different temperature conditions will disappear once they are returned to room temperature. Panels should not be exposed to sunlight. This is because excessive heat may cause them to deform.

Storage

Pallets

All variants are delivered on a pallet with a top protection panel. This ensures that the package does not bend during handling and protects the surface of the first panel from any loads.

If the panels are picked from the automatic warehouse and shipped with TFT panels, they will be placed on top of the TFT panels and covered with a protective sheet. The package will not bend too much during handling thanks to the TFT panels underneath.

The pallets should be stored indoors, ideally in the same packaging that was used to protect them during transport.

The pallets should be placed on shelves and not stacked on top of each other to avoid damaging the first sheets.

[→ FIG.01].

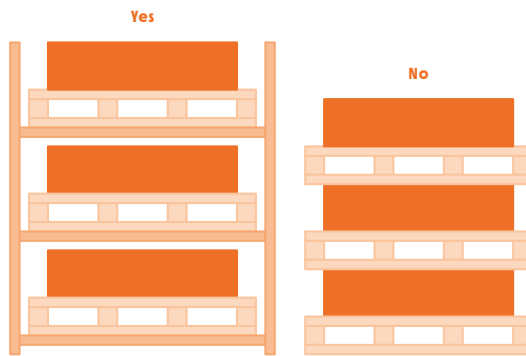

↑ FIG.01

Handling and transport

Pallets

The panels must be transported on **pallets**. The pallets must always be at least 5 cm longer and wider than the panels, and they must be rigid enough to prevent them from bending too much when lifted.

The panels must be **securely fixed** to the pallet with straps or another method so that they cannot slip during transport. This is particularly important since the **protective film** on the panels makes them smoother and more slippery.

Important!

- The **edges** of the panels are often sharp, so gloves should be worn when handling them.
- **Intense and direct sunlight should be avoided**, as excessive heat could cause them to deform.
- It is important that the pallets are not stacked on top of each other to **avoid excessive load pressure**, which would alter their flatness.
- Handle them with care to keep the **protective film** intact and prevent scratches. The film should be removed after machining and installation. In any case the film should be removed within six months from the delivery.
- **Outdoor storage** is not permitted as it may compromise flatness due to excessive heat and make it difficult to remove the protective film.

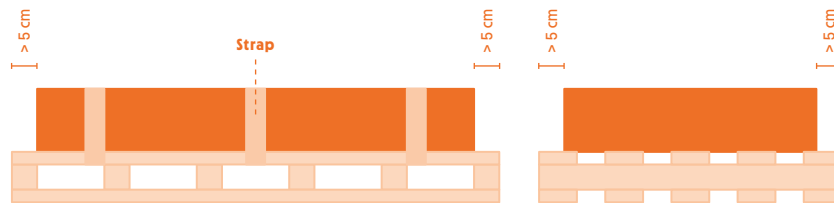

Cutting

The panel should be cut using either a **panel saw** or a **CNC machine**. When using a panel saw, make sure that you always cut the decorative surface first.

The **blades** should be diamond-tipped. The blade diameter should be between 25 and 45 cm.

The **cutting speed** should be between 2 and 3 metres per minute, with a blade rotation speed of approximately 3,000 rpm.

Edging

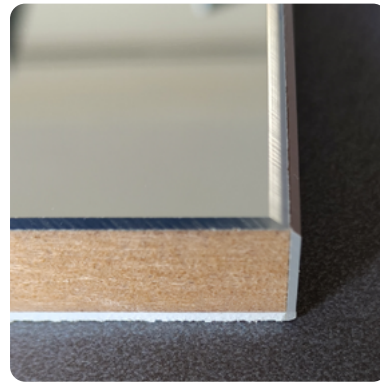

The best edging results are obtained by creating a **45°** or, even better, a **60°** bevel on the thickness of the PMMA and the edge to highlight its depth and transparency.

Some edging machines can create the bevel, but these are not very common. As an alternative, you can edge the piece as usual and then create the chamfer using a router or CNC machine. For an optimal result of light reflection, the bevel can be sanded or polished manually or with electric sanders.

The edge can be colour-matched or contrasting.

PVA glue sticks to the MDF thickness but not to the PMMA and PS thickness.

PU glue behaves much better.

Drilling

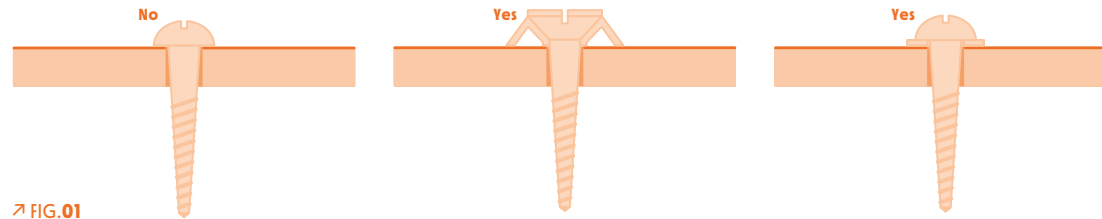

➤ FIG.01



➤ FIG.02

When drilling a panel particular care should be taken not to over heat the point of the drill, which could damage the surface.

Drill points should be helical with a point angle between 50° and 90°.

The holes diameter should always be **at least 0,4 mm larger than the one of the screws**, and **rubber or plastic washers** should be used to avoid direct contact between the screws and the panel surface, and which should give some allowance to the board dimensional variations due to changes of temperature or humidity [→ FIG.01].

The holes and the internal corners should never present sharp corners, which could cause cracking, but should always be rounded with the maximum radius possible [→ FIG.02].

Cleaning

Mirror, Ice & Glass panels can be **cleaned with a clean, soft and wet cloth**. If the stain is particularly difficult hot water or mild liquid detergent without abrasives could be used.

The panels normally charge with static electricity and therefore tend to attract dust.

Light dirt should be removed with a soft, non-abrasive, damp cloth without applying pressure to avoid scratches.

Glass cleaners or alcohol can be used and should be applied quickly and in small quantities.

Always check the chemical composition of any other detergents before use.

Cleaning should only be carried out on surfaces at room temperature and never in direct sunlight.

Aggressive chemicals include chlorinated solvents, acetone, feron, aromatic hydrocarbons and pure formic acid.

Chemicals to avoid include alcohols, white spirit, petrol, diesel, naphthalene, thinners, ether, ammonia, bleach and caustic soda.

SM 'art[®]
Surface Materials

www.s-m-art.it
info@s-m-art.it